



EDGE BANDER

SP-75

PRODUCT

USER MANUAL



ORDER NOW



More information
www.goldstarcnc.us



More information
(786)400-0910

CONTENT

GENERAL WARNINGS AND SYMBOL / 4

DESCRIPTION AND TECHNICAL SPECIFICATIONS / 5

INSTALLATION / 6

BASIC OPERATION PRINCIPLE / 7

MACHINE UNITS / 8 -18

OPERATING INSTRUCTIONS / 19

MAINTENANCE INFORMATION / 20

LIST OF MATERIALS / 21

TECHNICAL SERVICE / 22

DISCLAIMER OF WARRANTY / 23

ELECTRIC DIAGRAMS / 24



MACHINE

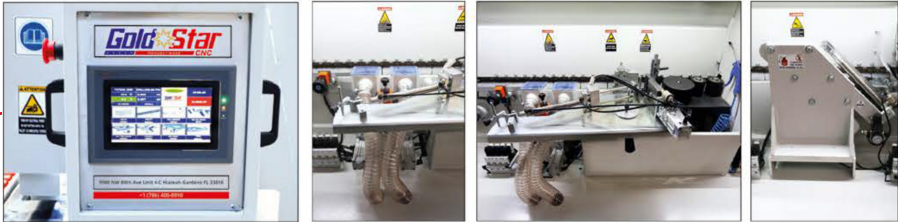

! DANGER!



- * Shut down the power.
- * Wait until the spindle blades stop.

! WARNING!



- * Shut down the power.
- * Wait until the pallet stop.

! DANGER!



- * Moving parts can crush and cut.
- * Keep your hands clear.

Do not operate the machine without getting out the workpiece from it.

! DANGER!



MOVING PARTS CAN CRUSH AND CUT.

- * Keep your hands clear.
- * Do not operate the machine before turning off the air blast switch.

! DANGER!



- * Shut down the power.
- * Wait until the spindle blades stop.

! DANGER!



- * Keep your hands away from blades while its running.
- * Be sure that the blades had stopped before interfering the machine.

! DANGER!



- * Shut down the power.
- * Wait until the spindle blades stop.



DO NOT PUT YOUR HANDS BETWEEN THE WORKPIECE AND THE MACHINE.



ELECTRICITY



DO NOT PUT YOUR HANDS BETWEEN THE GEARWHEELS.



PLC Screen

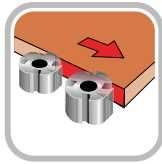

Pre Milling DIA

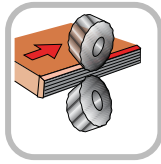

Polishing

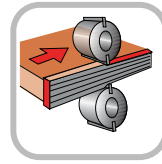

Top-Bottom Milling

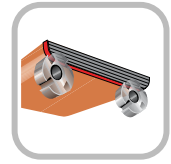

Rounding

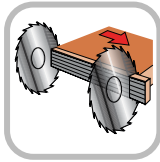

Head-End Cutting

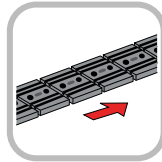

Pallet With Spindle

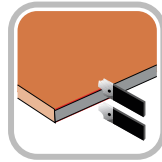

Radius Scraping

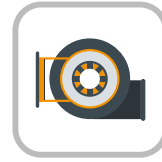

Dust Collector

A DESCRIPTION AND TECHNICAL SPECIFICATIONS OF THE MACHINE

EDGE BANDING MACHINE is produced for edge banding wooden materials by the use of its power motor, pneumatic systems and mechanic motor. In short, EDGE BANDING MACHINE's role is banding the edges in wooden furniture sector.

EDGE BANDING MACHINE's technical specifications and models are as follows:

SP-75 TECHNICAL SPECIFICATIONS

TECHNICAL SPECIFICATIONS	GLUE HEATING TIME (AVERAGE)	20 MIN
	SQUEEZE THICKNESS	0.015X0.125 IN
	SQUEEZE HEIGHT	2.4 IN
	PART DIMENSIONS TO BE SQUEEZED	4 3/4 X 5 15/16 IN
	OPERATING SPEED	60 FT X MIN
	PRE MILLING ENGINE SPEED	12.000 RPM
	FRONT-END CUTTING ENGINE SPEED	12.000 RPM
	FRONT-END CUTTING SAWS	80X20
	MILLING ENGINE SPEED (PER MINUTE)	12.000 RPM
	MILLING KNIFE	6 BLADES R3
	TRIM ENGINE X3	12.000 RPM
	TRIM KNIFE	6 BLADES R3
	RADIUS SCRAPING	R3
	POLISHING ENGINE SPEED	3.000 RPM
	ELECTRIC POWER	26 HP
	AMPERAGE/AMPERAJE	50 A
	REDUCER SPEED (PER MINUTE)	18 RPM
AIR PRESSURE	5 PSI	
GLUE TANK VOLUMEN	3 KGS	

DIMENSIONS	LENGTH	197 IN
	WIDTH	31 1/2 IN
	HEIGHT	55 IN
	WEIGHT	3086 lb

Basics

Installation of this machinery can only be done by authorized personnel.

Lay-out

- This machine should be kept indoors.
- Please make sure that the room temperature isn't too low in order to keep the machine working properly. Low temperatures can interfere with the adhesive product.

Electrical Installation

- Electrical installation of this machine must be done by the authorized personnel in accordance with the operating manual.

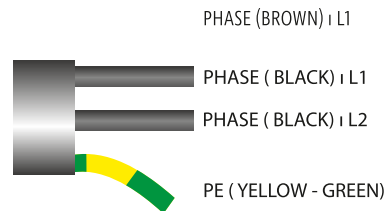

PICTURE 1

ELECTRICAL BONDING

- Make the electrical connection of the machine as in picture 1. As a result of incorrect connection, the electrical components of the machine may be damaged.

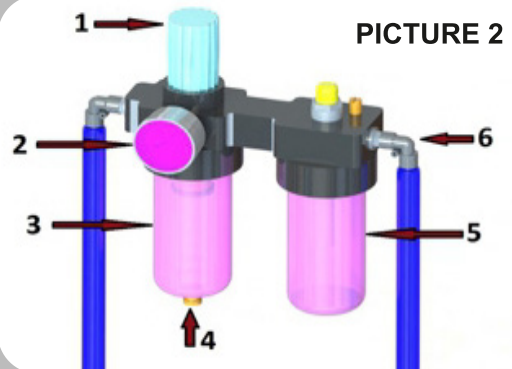

PICTURE 2

PNEUMATIC CONNECTION

Need air for the pneumatic system is sent by the compressor to the machine.

- 1) Stressing Adjustment:** It adjusts the air which is sent to the system.
- 2) Pressure Indicator:** It shows the air which is sent to the system.
- 3) Water Tank:** The air evaporates, and it is accumulated in here.
- 4) Water Evacuation Pump:** It is used for evacuating the water in tank.
- 5) Oil Sump:** The oil which is used for lubricating the machine's system is kept here.
- 6) Air Intake:** The air which is sent by compressor enters through here.

Note: You should use thin oil, number 10.

BASIC OPERATION PRINCIPLE

Routine controls that are set out below must be done before operating the machine.

- Control of the air that is sent by compressor.
- Emergency button mustn't be pressed.
- Machine doors must be closed.

CONTROL PANEL



You can control all units via plc touch screen.

ROTARY TABLE

It contains the edge band rolls and makes rolls' accession to the machine easier. It rotates around its own axis and feeds itself. It is assembled to the machine.

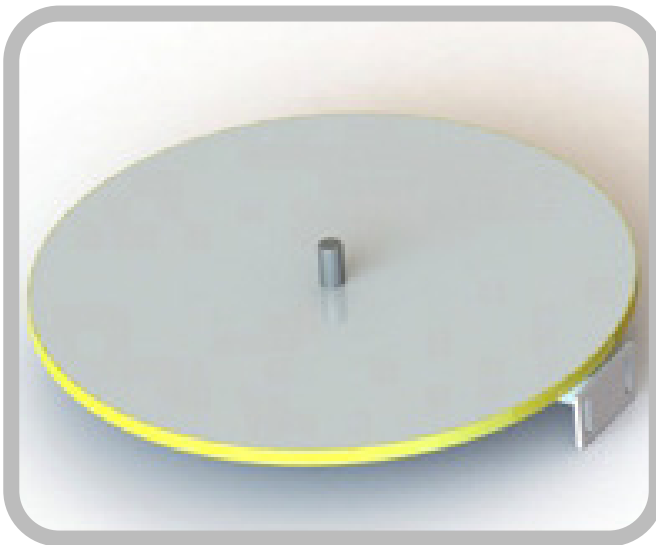

PRE MILLING UNIT

It cleans the surface that has possible cracks and burrs which is going to cover with band. This process makes banding easier.

You can move it up and down by using thumbwheel switch which is shown in figure 1.

Please take out front door to change the cutters.

Please fasten up the motor shaft with 22mm size open-end wrench as shown in figure 2.

Please loosen the screws, which are in the top, towards rotation of the motor. figure 3.

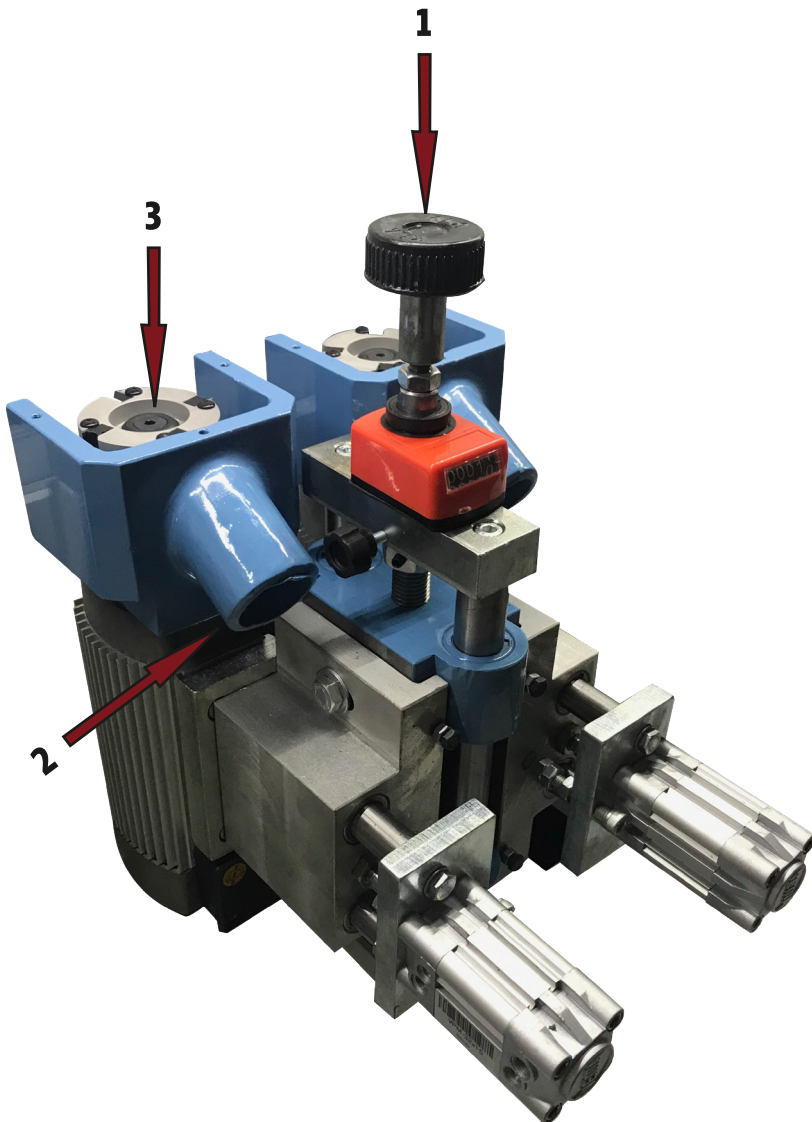

GLUE BOX

It smears glue on a workpiece. For the product to stick well and the edge band to be solid, it is important to pay attention to the melting temperature of glue. Heating resistance which is located in glue unit is used to reach the melting temperature of the glue.

According the brand you use, melting temperature can change. To avoid this problem, you should use a glue suitable with the machine. The degree of glue is indicated in this operating and maintenance manual as 170°C/338°F at minimum and 210°C/410°F at maximum.

Glue is a chemical composition and can lose its effect between the process of heating and cooling. You shouldn't fill the glue box with too much glue or you will risk it going to waste. You should add 100 to 150 grams (3-5oz) of glue in the box per 20 to 30 meters (65 to 100 feet).

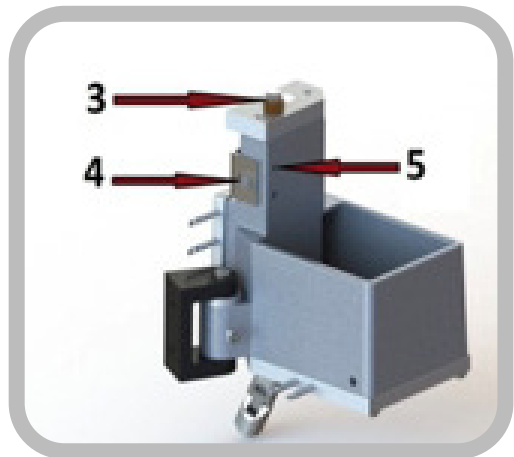
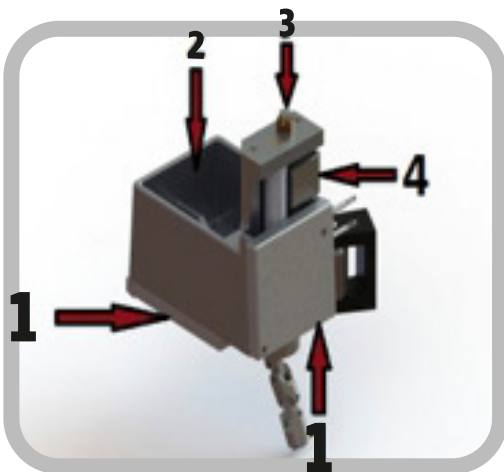

1) Resistances: It keeps the heating value of the glue same.

2) Glue Box: It keeps the glue itself.

3) Glue Control Lever: It adjusts the amount of glue used on a workpiece.

4) Tracer: It makes the workpiece pass without touching the mandrel's surface.

5) Tracer Screws: They keep the tracer in place.

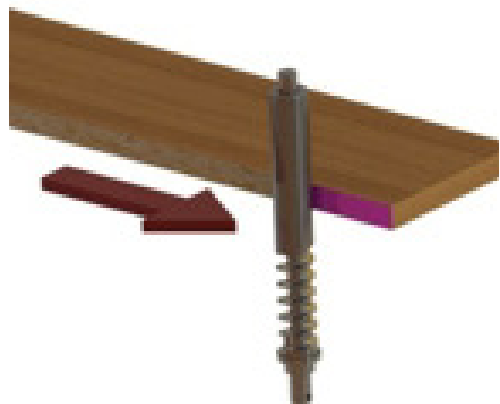

AUTOMATIC BANDING SYSTEM

Its function is banding and cutting the surface automatically.

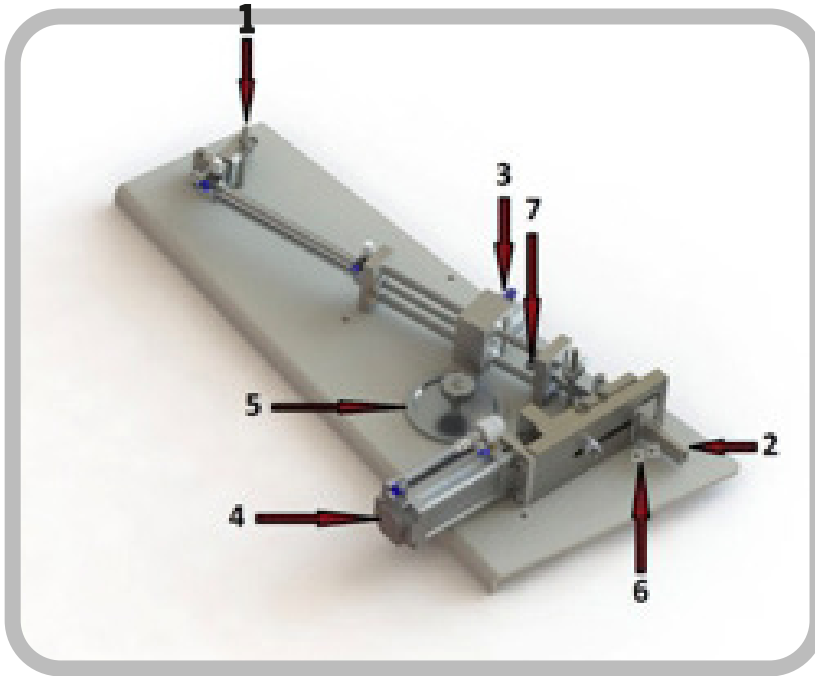

- 1) PVC Upper Compression Piece:** This piece enables back and forth movement of the PVC band.
- 2) Band Tracer Bushing:** Allows for the banding to be positioned properly.
- 3) Pneumatic Piston:** It holds and pulls the band for banding.
- 4) Automatic Shears:** It cuts the band automatically.
- 5) Glue Cap:** It is used for filling glue into the glue box.
- 6) Allen Screw:** It balances the band and the workpiece.
- 7) PVC Length Adjustment:** It adjusts the length of front and end of the band.

BANDING OPERATION SEQUENCE

- 1- Attach the PVC band into tape drive.
- 2- Put the band into the shears' spacing.
- 3- Put the material which is going to be banded into the pallet.

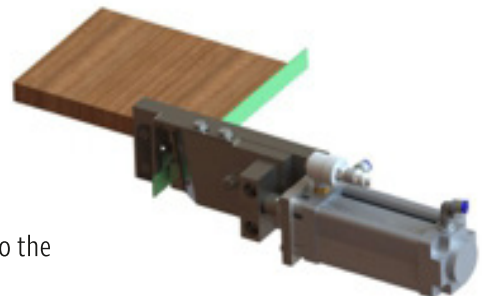

BANDING PRESS SYSTEM

Its function is pressing the band which is going to be stuck to the workpiece.

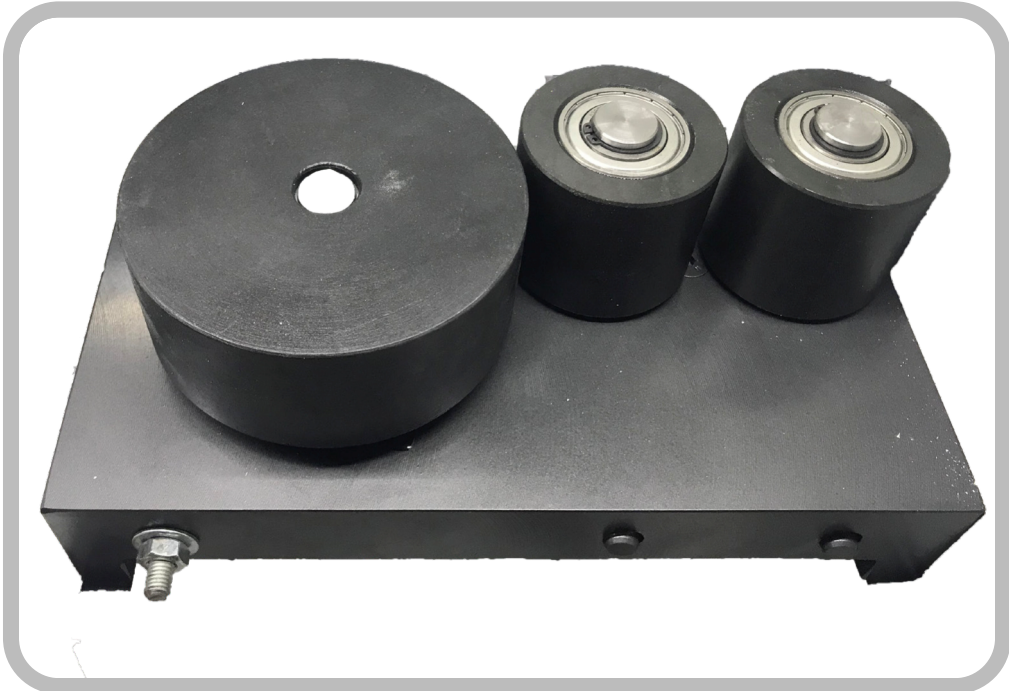

FRONT-END CUTTING SYSTEM

It cuts the workpiece with front end cutting system's unit named linear ray and drive system without causing any damage to the workpiece.

To adjust front end cutting motor's saw, loosen the screws on motor (figure 1) and adjust the screws, which is located in the back, by moving it back and forth (figure 2).

A Front cutting motor.

B End cutting motor.

Note: Please grease the linear rays with oil which should be number 10. While pressure clock that is on the unit motors is working, the pressure level should be 3 bars (figure3).

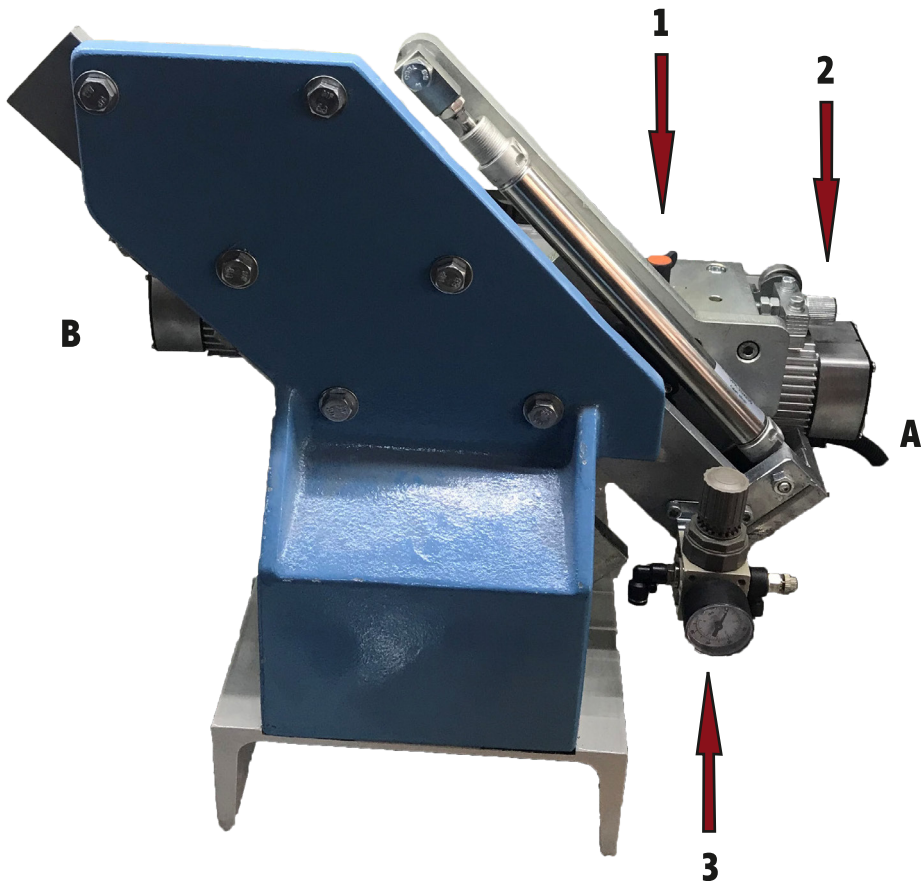

BOTTOM-TOP PHASE GROUP

Adjustment which can be done in a short time is very important for the user. It enables the ease of use when adjusting it to 2mm from 0.40mm by the help of thumbwheel switch.

To adjust the thumbwheel switch (figure 1) according to the thickness of PVC (figure 2), please unfasten and adjust it for measuring range.

Please unfasten it (figure 3) and by using the screw, adjust immersion and knurl on the surface of workpiece, figure 4.

Loosen the motor's screws to change blades, then screw them again.

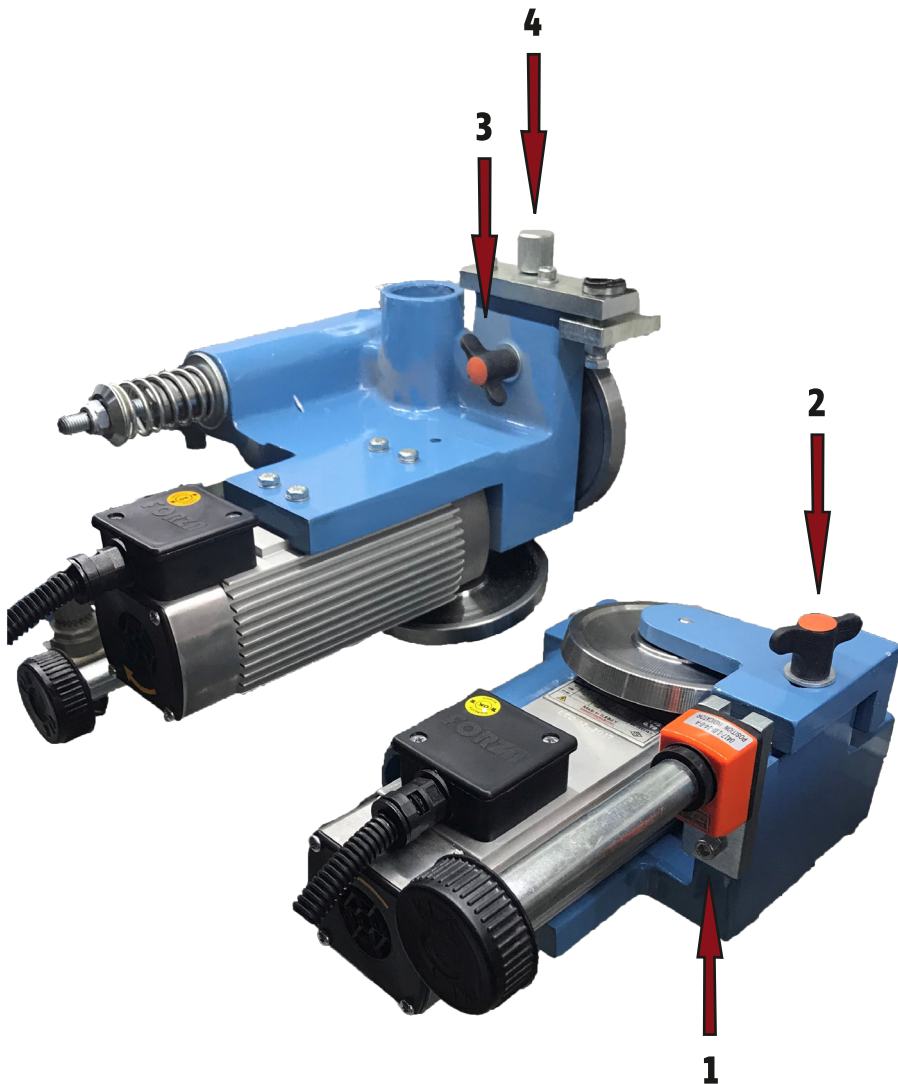

RADIUS SCRAPING UNIT

Its function is erasing the blade scars which occurs after edge banding by the help of scraping unit and the cleaning of surface by phases.

During the scraping process, R3 blades are used. At the same time, it offers a big advantage thanks to the system which has frontal and ball tracer that works on the surface at maximum quality.

To adjust thumbwheel switches (figure 1) according to PVC thickness, unfasten it (figure 2) after adjusting its measure, fasten it again.

To adjust immersion and knurl measurement (figure 4), firstly unfasten it (figure 3).

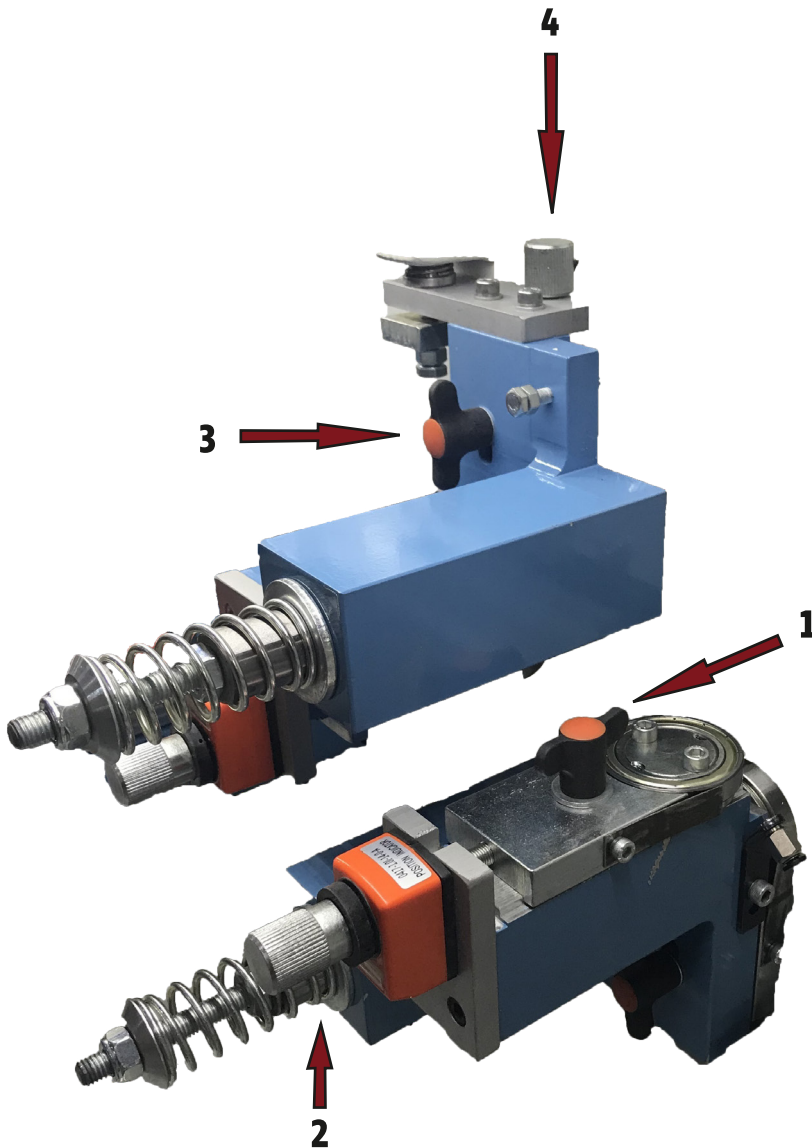

POLISHING SYSTEM

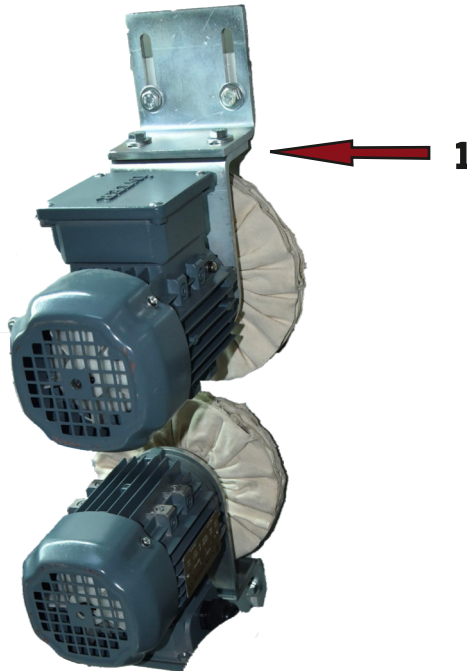

Polishing System: It erases the glue remains and polishes the surface and the band.

1) When the screw is unfastened, polishing system moves back and forth, up and down.

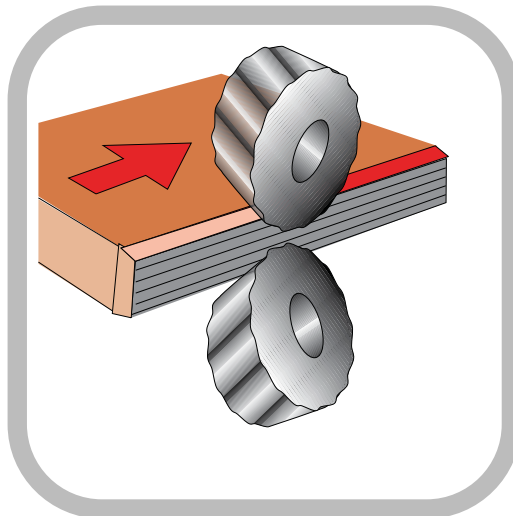

OVER PRESSURE AND APPRENTICE SYSTEM

1) Over Pressure Control Lever: It is used for adjustment of the workpiece's thickness. By turning this control level, workpiece's thickness can be adjusted when its thickness measurement changes.

2) Over Press: It pressures the workpiece from top of it.

3) Apprentice System: It enables the workpiece to move forward in a correct and balanced fashion when put into the machine. It is an important piece while using wide workpieces.

4) Fastening Apprentice System: It is the screw that is used to fasten the apprentice system for a certain measurement.

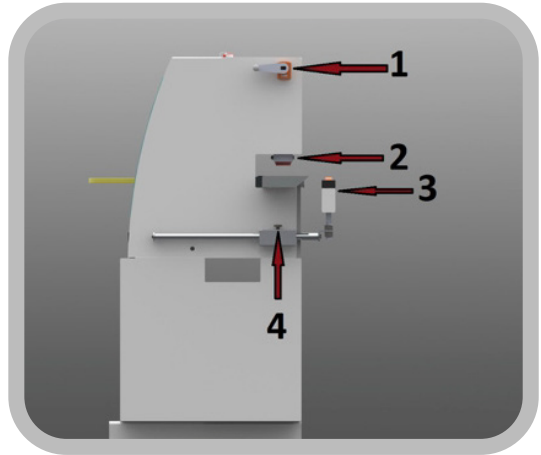

BOTTOM-TOP TRIM GROUP

Adjustment which can be done in a short time is very important for the user. It enables the ease of use when adjusting it to 2mm from 0.40mm by the help of thumbwheel switch.

It adjusts the radius of crooked edged of the flat pieces' points of junctions, softforming and postforming.

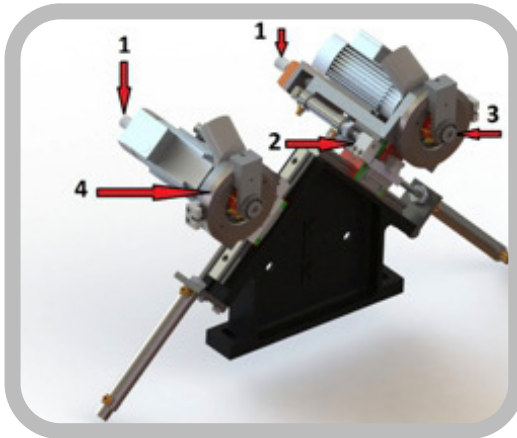

- 1) Pvc Thickness Thumbwheel Switch:** It is used for adjusting the band thickness.
- 2) Stabilizer Screw:** It is used for stabilizing the motor.
- 3) Top Tracer Ball:** It traces the workpiece from top of it and prevents blade from sticking in it.
- 4) Frontal Tracer:** It puts strain on frontal surface of the workpiece for contacting the blade.

EXAMPLES OF SOME WORKPIECES

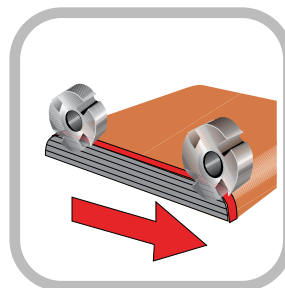
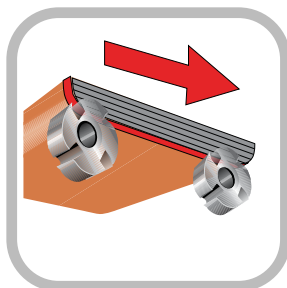

Starting Instructions

- ❗ To avoid causing any harm to humans the grid line which is used for the connection of the machine must be grounded.
- ❗ Do read this manual before running the machine. If you have any problem regarding mechanical, electrical or pneumatic errors, please get help from this manual. If you cannot fix it by your own, do not hesitate to contact us.

Operating Instructions

- Please do not run the machine before heating it up (20 min approx.).
- Run the machine after heating up.
- Wooden material which is going to be banded must positioned into the pallet unit correctly.

Shut Down Instructions

- Do not shut down main switch before stopping all the units.
- Press EMS button in case of emergency to shut it down.

Safety Instructions

- Please check the machine before running it.
- This machine must be used by only designated operators.
- Do not intervene with the machine while it is running.
- The operator shouldn't leave his workplace while the machine is running.
- Machine's maintenance must be done by only authorized personnel. Please contact us if you receive an error.

HOUSING AND TRANSPORTATION INSTRUCTIONS

- Machine must be carried by a crane or forklift in accordance with the machine's weight.
- It must be transported via trucks.
- Before transporting, the machine must be partly wrapped with plastic foil.
- During transportation do not put something on the machine.
- Please do not expose the machine to any damage during the transportation.

CAUTION: Hazard symbols and texts are placed into the package. Please note them.

Maintenance And Service

- Maintenance of the machine must done by the authorized personnel.
- Insufficient or wrong maintenance can cause errors. In this case the machine will be out of service and you cannot use it for a long time. Also, its repair cost will be very high. For this reason, periodic maintenance is very important.
- Frequency of maintenance, wear control or service can change due to its operating condition. Please organize these conditions according to machine's operating condition.
- Contact us in any problem about settings if machine's pneumatic system is not intervened.

Daily Maintenance

- After stopping the machine please clean its surface.

Weekly Maintenance

- Clean machine's surface.
- Grease the necessary parts with thin oil if necessary.

Monthly Maintenance

- Grease the necessary parts with thin oil if necessary.
- Change the blades if they are wearing.
- Stretch the pallet if it loosens.

Yearly Maintenance

- Change the blades if they are wearing.
- Change the pallets and wheels if they are worn.
- Clean glue box.
- Change the parts that are worn.
- Contact us for yearly maintenance which is done by our authorized service personnel.

Name of the Material	Material's Function	
Control Panel	Controls the units of the machine.	
Reducer	Enables the movement of pallet system.	Ready
Pallets and Wheels	Rubber material that carries processed workpiece.	Ready
Gearwheels	Enables the movement of pallet system.	
Transmission housing	Sliding gears' housing.	
Glue Box	Melts the glue and prepare it for the use.	
Tape Drive	Drives band automatically.	
Shears	Cuts the band automatically.	
Start/Stop Buttons	Give energy to the units.	Ready
EMS Buttons	The one can press it in case of emergency.	Ready
Main Switch	Starts the machine.	Ready
Contactors	Moves and closes the flow.	Ready
Thermic	Controls reducer's flow.	Ready
Phase Protect Relay	Controls phases.	Ready
Speed Control Tools	Runs frequency motors.	Ready
Connectors	Connects the cables.	Ready
Switches	Orders valves.	Ready
Frequency Motors	Works with saws and blades.	Ready
Polishing Motors	Motors of polishing mats.	Ready
Lights	Lighten indoors.	Ready
Motor Connection Sheet	Holds motors.	
Linear Ray	Enables the movement of front-end cutting group.	Ready
Linear Drive	Holds motor connection sheets.	Ready
Main Casting Chassis	Holds all parts of the front-end cutting system.	
Saws	Cuts front and end of the band.	Ready
Radius Blades	Processes redundancies of band.	Ready
80x60 Aluminium Wedge	Houses phase and scraping units.	
Sliding Bearing	The balls inside of housing parts.	Ready
Boots	Gathers remains during the process.	
Dedusting Fan	Evacuates the remains.	Ready
Valves	Controls pneumatics of the units.	Ready
Pistons	Enables movement of the units.	Ready
Conditioner	Adjusts the stress.	Ready
Air hose	Carries air into the pistons.	Ready
Unions	The pieces which are attached to pistons and valves.	Ready
Polishing	The mats which polishes the materials.	Ready
Chromite Spindles	Carries apprentice table.	Ready
Apprentice Table	Supports wide materials.	
Rotary Table	Carries the band.	
Back and Forth Screws	Used for adjusting phase and trim motors.	
Clamping Plastics	Used for fastening doors.	Ready
Saw Coverings	Used for preventing any damage.	
Wheel Pressure	It is attached to the part which presses workpiece.	
Mandrel	Applies glue into the workpiece.	
Trunnions	Moving parts which works between the mills.	
Tracers	Enables to motors' starting by tracking the workpiece.	



CAUTION!

Producing Company's Title

Goldstar CNC

SPARE PARTS AND AFTER-SALES DEALER SUPPORT

As a machine manufacturer, since the first day of our establishment, we record the machine's features that we import such as its import date and firm without delay.

We will be glad to provide the spare parts for you by our service unit. In this case, please contact us via phone or fax.

CONTACT US



More information
www.goldstarcnc.us



More information
(786)400-0910

DISCLAIMER OF WARRANTY

This product's warranty, provided by **Goldstar CNC** If any of the malfunctions are caused by user carelessness we will provide repair and/or replacement services for a fee regardless of warranty period.

Out of the scope of the present warranty will be any damages and malfunctions of the EDGE BANDING MACHINE which have their origin in:

- Negligent, improper or inadequate use.
- Damages due to surge, floods, plagues, earthquakes, third parties' actions, or any other reasons.
- Modifications or repairing attempts that were not been held by authorised personnel by the After Sales Service.
- Not following instructions given in the operating and maintenance manual.
- Wrong installation or improper removal procedure.
- Malfunctions like wearing, operating the machine wrongly or forcing machine's capacity.
- Misapplied changes and modifications that affects its function.
- Running the phase's and saw's motors when the workpiece in it.
- Electronical pieces which can be damaged by wrong electrical connections.

NOTE:

- All material and manufacturing defects which arises from manufacturer's fault of the machine are the scope of warranty under the legal provisions.
- Malfunctions arises from materials are recuperated by renewing or repairing it.

The malfunctions' that are mentioned above troubleshooting and providing services are not the scope of warranty.

This product's warranty, provided by **Goldstar CNC** covers a period of 2 years from the date of purchase. All faulty parts and/or functions, resulting despite user's normal use, will be repaired and/or replaced at no charge during the warranty period. You can provide spare parts or technical service from us for fee for 10 years from the day warranty expired.

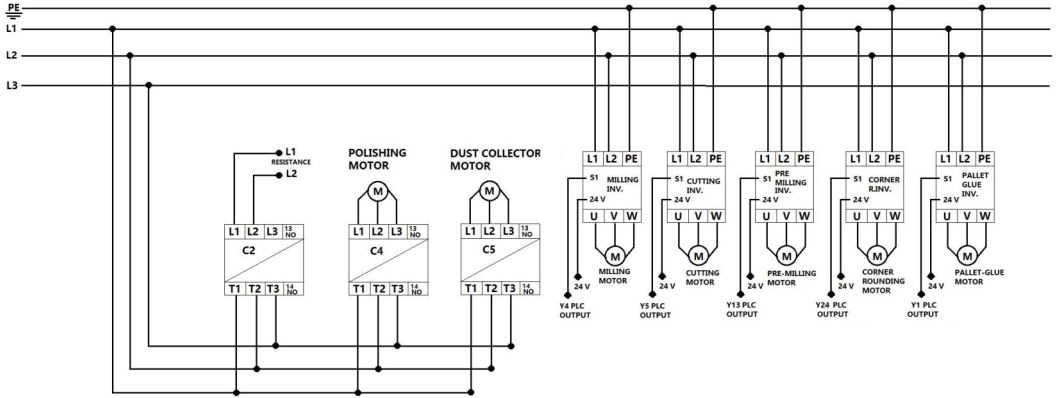

SP-75 POWER CIRCUIT

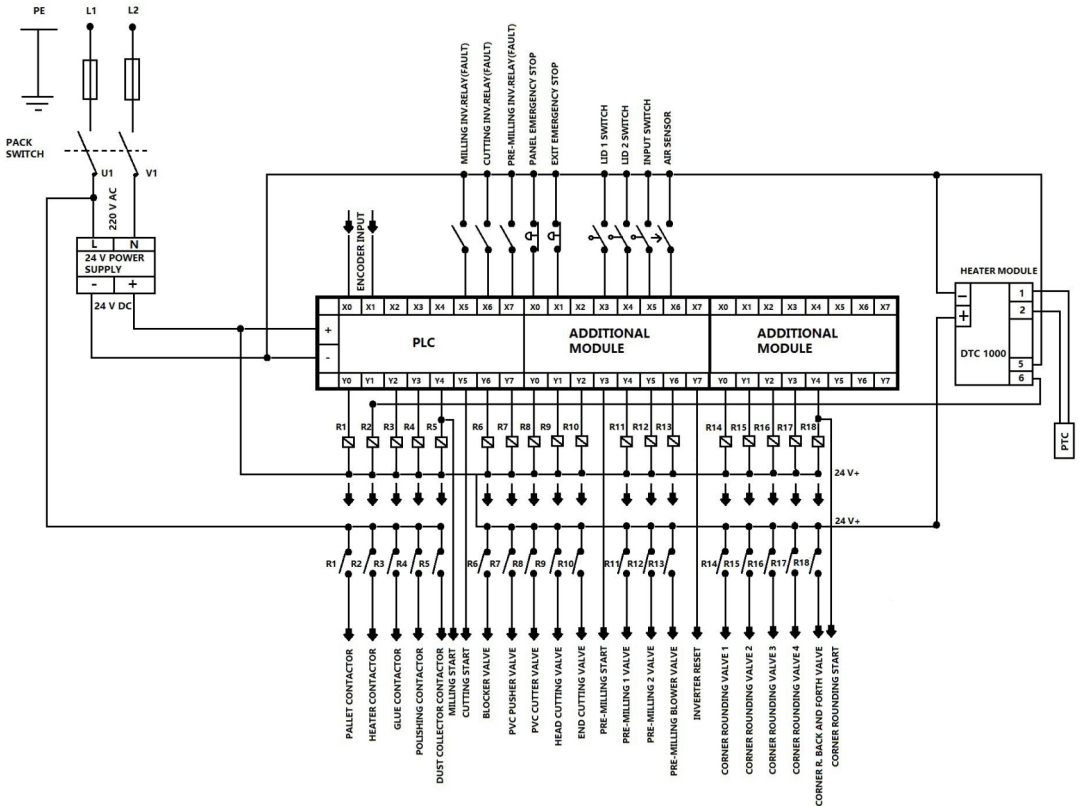

SP-75 CONTROL CIRCUIT



ORDER NOW



More information
www.goldstarcnc.us



More information
(786)400-0910